

SGA/A & SGA/D Manual

Contents

Chapter 1 Introduction to SGA/A & SGA/D	2
Figure 1.1 SGA Signal Conditioner	2
Chapter 2 Installing the SGA/A & SGA/D	3
Pre Installation	3
Figure 2.1 Dimensions	3
Cabling	4
Power Connection.....	4
Figure 2.2 Power Connection.....	4
Figure 2.3 Input (Sensor) Connections	5
Table 2.1.....	5
Output Connections.....	6
Figure 2.4 Output Connections	6
Chapter 3 Settings	7
Figure 3.1 Output Settings–Switch 4.....	7
Table 3.1 Output Option	7
Table 3.2 Switch 4.....	7
Table 3.3.....	8
Output Filter Settings –Switch 3.....	8
Table 3.4 Switch 3.....	8
Table 3.5.....	9
Output Current Mode Settings – Jumpers JP1 & JP2	9
Figure 3.2	9
Span (Gain) Setting Switch 1	10
Table 3.6 – SW1.....	10
Span (Gain) Setting Switch 1.....	11
Table 3.7.....	11
Zero (Offset) Setting Switch 2.....	11
Table 3.8.....	11
Table 3.9.....	11
Chapter 4 Calibration	12
Sensitivity	12
Figure 4.1 Calibration Connections using Millivolt Source	14
Chapter 5 Troubleshooting	15
Chapter 6 Product Care	17
Chapter 7 Glossary	18
Chapter 8 Specifications for SGA/A & SGA/D Load Cell Amplifiers	21
WARRANTY.....	22
Other Mantracourt Products	24

Chapter 1 Introduction to SGA/A & SGA/D

The Strain Gauge Amplifier SGA.

The SGA is a Strain Gauge Amplifier, converting a strain gauge input to a Voltage or current output – otherwise known as a Signal conditioner.

The SGA provides a wide range of signal conditioning for Strain gauges, Load cells, Pressure and Torque transducers.

Figure 1.1 SGA Signal Conditioner

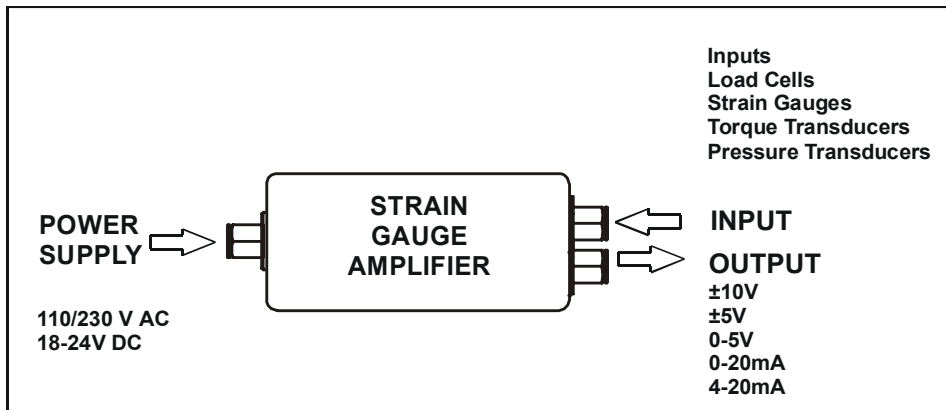

Offered in two versions, the SGA/A for 110/230V AC or 18-24V DC operation and the SGA/D which is DC powered only.

Transducer **SENSITIVITY** of between 0.1 mV/V and 30 mV/V are possible. This is achieved by a combination of gain (span) DIP switches and associated *fine adjustment* by a potentiometer.

Similarly transducer zero **OFFSET** and **SCALE DEAD BAND** of up to 79% can be compensated for in the module. This is achieved again by a combination of zero DIP switches and associated *fine adjustment* by a potentiometer.

The module has built-in **FILTERS** to cancel the field effects of vibration, agitation and electrically noisy environment. The on-board low pass filter can be switched in and adjusted (from 1Hz to 5kHz) using a series of DIP switches.

A wide range of proportional output options for currents and voltages can be configured by DIP switch settings.

Both the AC and DC versions are based on a common board and are mounted in an IP65 (NEMA 4X) ABS case.

Chapter 2 Installing the SGA/A & SGA/D

Pre Installation

See Specification details in Chapter 8 for details of Environmental Approvals.

Carefully remove the SGA/A unit from its packing. Check that the unit is complete and undamaged.

The SGA/A & SGA/D units can be operated in any industrial environment providing the following limits are not exceeded

Operating Temperature	-10 °C to +50 °C
Humidity	95% non condensing
Storage temperature	-10 °C to +50 °C

While the unit is sealed to IP65 (NEMA 4X) it is advisable to follow the following installation practice where possible

- Minimise vibration.
- Do not mount next to strong electrical fields (transformers, power cables)
- Ensure easy access to interior of the module
- Install electrical protection device, as the unit is not internally fused.
- Always ensure the lid is properly fitted and all 4 screws tightened.
- Always ensure the cable gland is sealing against the cable to maintain the IP (NEMA) rating.

Figure 2.1 Dimensions

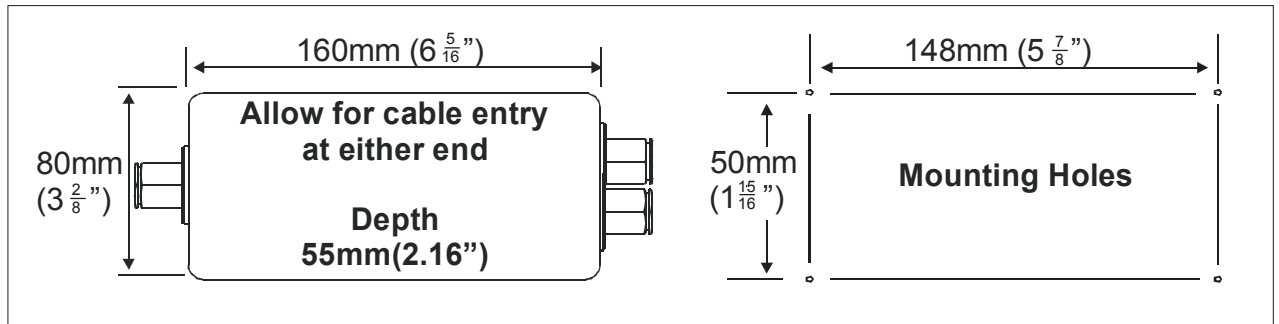

The 4 screws for the lid are captive and must be tightened to maintain the seal.

The holes for the mounting screws in the base are directly behind the screws for the lid.

The box must not be drilled as this would invalidate the IP rating

Allow sufficient space at both sides for the cable entry.

The Nylon 66 cable glands are designed for ROUND cables.

The waterproof entry and strain relief will seal to a higher rating than the enclosure.

Cable diameter should be between 4mm (0.16 inches) and 7mm (0.27 inches)

Cabling

Power Connection

Two power supply options are available

SGA/A: 220/230VAC, 50/60Hz
110/120VAC, 50/60Hz
5W Max.

SGA/A & SGA/D: 18-24V DC, 5W (approx. 150mA fully loaded)

NOTE: The SGA/A can be powered from AC or DC sources whichever is available.
It is also possible to connect BOTH AC and DC simultaneously for security of power supply.

Figure 2.2 Power Connection

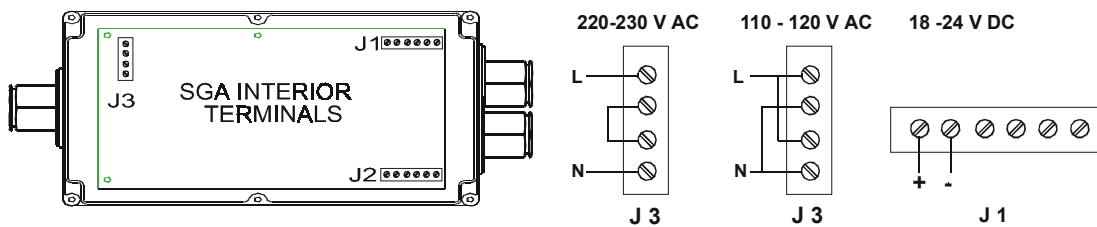

Standard mains 2 or 3 core cable PVC sheathed (unscreened) cable will suffice for the power.

NOTE: Connect appropriate power to the SGA (AC to J3, observe correct transformer jumper placement as shown in Figure 2.2 above).
(This diagram is also provided inside the module lid).

Connections to the SGA/A & SGA/D input/output signal and the power supply are made via 2.5mm² field terminal blocks.

Cable entry in the cased versions is via glands in the side of the case.

Figure 2.3 Input (Sensor) Connections

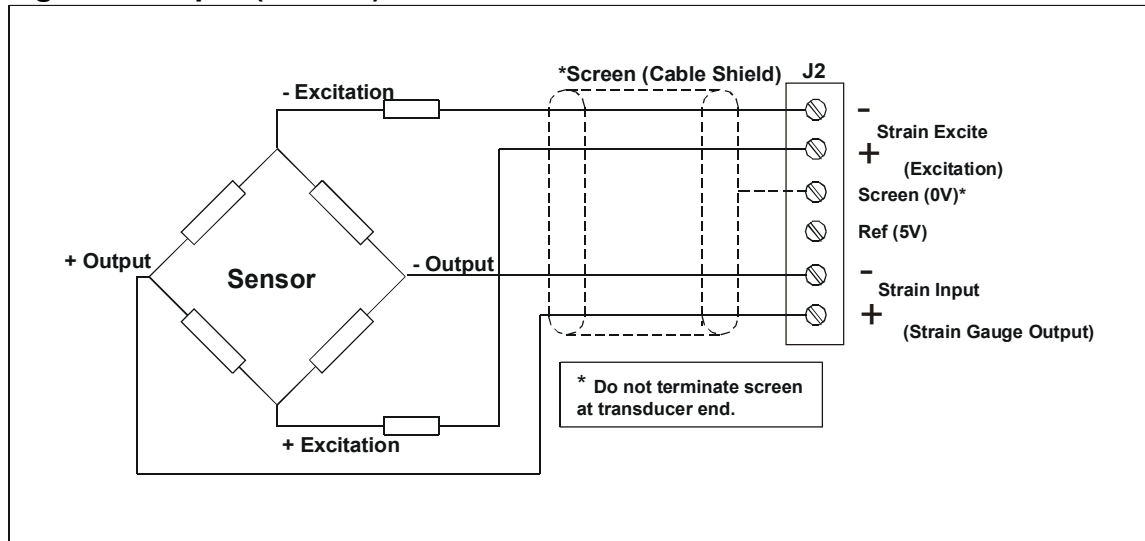

NOTE:	Strain excite is Excitation to the transducer. Strain input is Signal from the transducer. The Ref 5V is generated internally and used for calibration
-------	--

The cable connecting the sensor to the SGA should be screened.
This typical cable data is provided for information only.
The cable should have 2 x twin twisted cables. Ideally with each pair individually screened and with an overall screen.

Table 2.1

Country	Supplier	Part No	Description
UK	Farnell	148-539	Individually screened twisted multipair cable (7/0.25mm)- 2 pair Tinned copper drain. Individually screened in polyester tape. Diameter: 4.19 mm Impedance: 54 Ohms: Capacitance/m: core to core 115 pF & core to screen 203 pF
UK	Farnell	585-646	Individually screened twisted multipair cable (7/0.25mm)- 3 pair Tinned copper drain. Individually screened in polyester tape. Diameter: 6.86 mm Impedance: 62 Ohms: Capacitance/m: core to core 98 pF & core to screen 180 pF
UK	RS	367-533	Braided screened twisted multipair cable (7/0.2mm)- 1 pair Miniature- twin -round Diameter: 4.8 mm Impedance: 62 Ohms: Capacitance/m: core to core 120 pF & core to screen 210 pF

If possible segregate the signal cable from Power Cables; allow a 1meter (3 foot) distance from such cables.
Do not run signal cable in parallel with power cables and cross such cables at right angles.

The earth connection conductor should have sufficient cross-sectional area to ensure a low impedance path to attenuate RF interference.

Output Connections

Two analogue outputs are available from the SGA, proportional DC current and DC voltage. The ranges available are as follows: -

Output	Range	
DC voltage	±10V ±5V 0 - 10V 0 - 5V	NB: Maximum Load on voltage ranges is 2mA.
DC current	0 - 20mA 4 - 20mA	NB: Maximum impedance 500R.

The DC current support both 'sink' and 'source' modes of operation. Two jumpers JP1 & JP2 provide the means of selecting the desired mode.

Figure 2.4 Output Connections

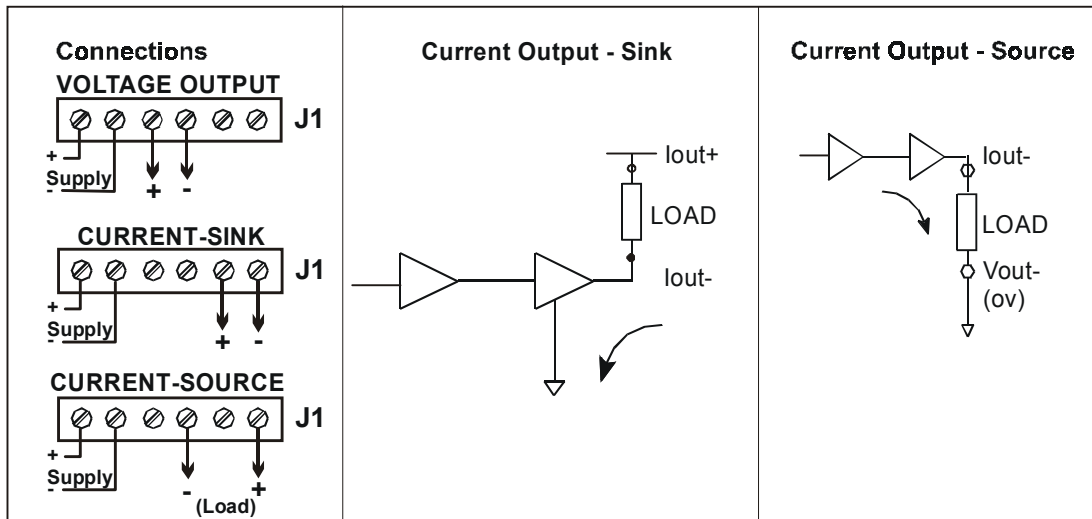

In '**Sink**' mode the +ve end of the load is connected to the internal +15V supply on the SGA and the -ve end is connected to the SGA output. The current through the load is 'sunk' by the SGA towards ground (0V).

N.B. In this mode neither connection to the output load is electrically common to the load cell. Select this option by fitting the two jumpers in the positions next to the capacitor (See Figure 3.2)

In '**Source**' mode the +ve end of the load is connected to the SGA output and the current is 'sourced' by the SGA output through the load towards ground (0V).

This mode has the advantage that the negative output connection is common to the load cell '- Excitation' terminal.

Select this option by fitting the two jumpers in the positions furthest from the capacitor (See Figure 3.2)

In this mode connect the +ve end of the output to 'lout-' and the -ve end to 'Vout-'.

See Chapter 3 for Switch settings and details of SINK & SOURCE jumpers.

Chapter 3 Settings

Figure 3.1 Output Settings–Switch 4

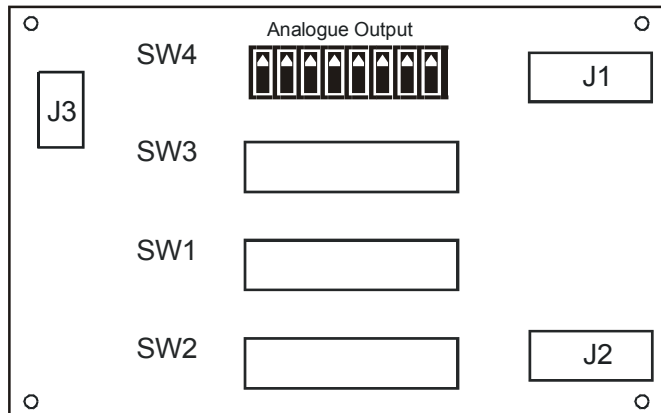

Use switch 4 to select the required output and, if required, the low pass filter.
(Switches in above Figure 3.1 are all 'ON')

Table 3.1 Output Option

Input Range	Output Option					
	4-20mA	0 to 20mA	0 to 10V	0 to 5V	±10V	±5V
+	20mA	20mA	10V	5V	10V	5V
↑	↑	↑	↑	↑	↑	↑
0	4mA	0mA	5V	2.5V	0V	0V
↓			↓	↓	↓	↓
-			0V	0V	-10V	5V

NB. Full scale output for the voltage ranges is achieved with a bi-polar (\pm) input

Switch Positions



Table 3.2 Switch 4

Analogue Output Options - SW4								
SW4	1	2	3	4	5	6	7	8
±10V	0↓	0↓	0↓	X	X	1=Filter	1=No Filter	X
±5V	0↓	1↑	0↓	X	X	1=Filter	1=No Filter	X
0-10V	0↓	1↑	1↑	X	X	1=Filter	1=No Filter	X
0-5V	1↑	1↑	1↑	X	X	1=Filter	1=No Filter	X
0-20mA	X	X	X	0↓	0↓	1=Filter	1=No Filter	X
4-20mA	X	X	X	1↑	1↑	1=Filter	1=No Filter	X
Filter out	X	X	X	X	X	0↓	1↑	X
Filter in	X	X	X	X	X	1↑	0↓	X

Switch settings (0 = Off 1 = On X = Don't Care)

Important: Low pass filtering is switched into operation by setting SW4/6 'ON'↑ and SW4/7 'OFF'↓.
Reverse these settings to bypass the filter.
It should be noted that either one of these switches MUST be on but not BOTH

Example :- 0-10 Volt output with no filter required.

Table 3.3

SW4	1	2	3	4	5	6	7	8
0-10V	0 ↓	1 ↑	1 ↑	X	X	0 ↓	1 ↑	X

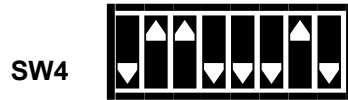

Output Filter Settings –Switch 3

The unit incorporates a second order low pass filter which can be switched in to improve the performance and output signal quality in electrically noisy environments.

It can also be used to reduce the effects of high frequency fluctuations in the load or applied force to the load cell.

The cut off frequency of the filter is set by the DIP switch SW3 as illustrated in the table below

Table 3.4 Switch 3

SW3	1	2	3	4	5	6	7	8
1Hz	0 ↓	0 ↓	0 ↓	0 ↓	0 ↓	0 ↓	1 ↑	1 ↑
5Hz	1 ↑	0 ↓	0 ↓	0 ↓	0 ↓	1 ↑	1 ↑	1 ↑
10Hz	1 ↑	1 ↑	0 ↓	0 ↓	1 ↑	1 ↑	1 ↑	1 ↑
50Hz	1 ↑	1 ↑	1 ↑	1 ↑	1 ↑	1 ↑	1 ↑	1 ↑
100Hz	0 ↓	0 ↓	0 ↓	0 ↓	0 ↓	0 ↓	0 ↓	0 ↓
500Hz	1 ↑	0 ↓	0 ↓	0 ↓	0 ↓	1 ↑	0 ↓	0 ↓
800Hz	see note**							
1kHz	1 ↑	1 ↑	0 ↓	0 ↓	1 ↑	1 ↑	0 ↓	0 ↓
5kHz	1 ↑	1 ↑	1 ↑	1 ↑	1 ↑	1 ↑	0 ↓	0 ↓

** NOTE:

A SECONDARY low pass filter, with a cut off frequency of 800Hz, can be switched into the transducer by setting SW1/8 'ON' ↑

Important:	Low pass filtering is switched into operation by setting SW4/6 'ON' ↑ and SW4/7 'OFF' ↓. Reverse these settings to bypass the filter. It should be noted that either one of these switches MUST be on but not BOTH
------------	---

Example :-

A cut-off frequency of 50 Hz setting is illustrated below. *NOTE : SW4/ 6 must be 'ON'.*

Table 3.5

SW3	1	2	3	4	5	6	7	8
50Hz	1 ↑	1 ↑	1 ↑	1 ↑	1 ↑	1 ↑	1 ↑	1 ↑



Output Current Mode Settings – Jumpers JP1 & JP2

Figure 3.2

Refer to Chapter 2.4 for details of wiring connections for the output.

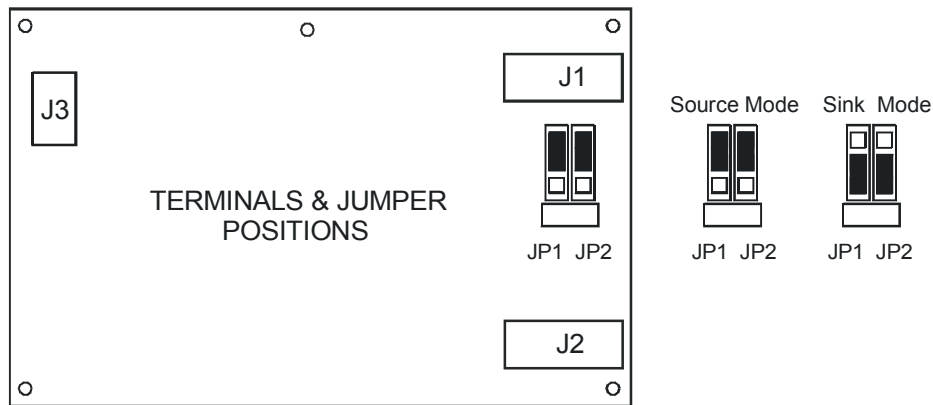

Span (Gain) Setting Switch 1

Ranges 1 to 60 – from 0.06 mV/V to 30.30 mV/V

↑ = ON (1) and ↓ = OFF (0). SW1/8 (x) = 800 Hz filter

Table 3.6 – SW1

1 0.06 mV/V 12345678 ↓↑↑↑↓↓↑x	2 0.11 mV/V 12345678 ↑↑↑↑↓↓↑x	3 0.17 mV/V 12345678 ↓↓↑↑↓↓↑x	4 0.23 mV/V 12345678 ↑↑↓↓↓↑↑x
5 0.28 mV/V 12345678 ↓↑↓↑↓↓↑x	6 0.31 mV/V 12345678 ↓↑↑↑↓↓↓x	7 0.34 mV/V 12345678 ↑↓↓↑↓↓↑x	8 0.39 mV/V 12345678 ↓↓↓↑↓↓↑x
9 0.44 mV/V 12345678 ↑↑↑↓↓↓↑x	10 0.50 mV/V 12345678 ↓↑↑↓↓↓↑x	11 0.55 mV/V 12345678 ↑↓↑↓↓↓↑x	12 0.60 mV/V 12345678 ↓↓↑↓↓↓↑x
13 0.61 mV/V 12345678 ↑↓↑↑↑↓↓x	14 0.65 mV/V 12345678 ↑↑↑↓↓↓↑x	15 0.70 mV/V 12345678 ↓↓↓↓↓↑x	16 0.75 mV/V 12345678 ↑↓↓↓↓↑x
17 0.75 mV/V 12345678 ↓↑↑↑↑↑↑x	18 0.80 mV/V 12345678 ↓↓↓↓↓↑x	19 0.91 mV/V 12345678 ↓↓↑↑↓↓x	20 1.20 mV/V 12345678 ↑↑↓↑↓↓x
21 1.41 mV/V 12345678 ↑↓↑↑↑↑↑x	22 1.49 mV/V 12345678 ↓↑↓↑↓↓x	23 1.78 mV/V 12345678 ↑↓↓↑↓↓x	24 1.99 mV/V 12345678 ↓↓↑↑↑↑x
25 2.07 mV/V 12345678 ↓↓↓↑↓↓x	26 2.35 mV/V 12345678 ↑↑↑↓↓↓x	27 2.49 mV/V 12345678 ↑↑↓↑↑↑x	28 2.63 mV/V 12345678 ↓↑↑↓↓↓x
29 2.91 mV/V 12345678 ↑↓↑↓↓↓x	30 2.95 mV/V 12345678 ↓↑↓↑↑↑x	31 3.19 mV/V 12345678 ↓↓↑↓↓↓x	32 3.35 mV/V 12345678 ↑↓↓↑↑↑x
33 3.46 mV/V 12345678 ↑↑↓↓↓↓x	34 3.72 mV/V 12345678 ↓↓↓↑↑↑x	35 3.73 mV/V 12345678 ↑↓↓↓↓↓x	36 4.00 mV/V 12345678 ↑↓↓↓↓↓x
37 4.00 mV/V 12345678 ↓↑↑↑↑↓x	38 4.05 mV/V 12345678 ↑↑↑↓↑↑x	39 4.26 mV/V 12345678 ↓↓↓↓↓↓x	40 4.36 mV/V 12345678 ↓↑↑↓↑↑x
41 4.63 mV/V 12345678 ↑↓↑↓↑↑x	42 4.89 mV/V 12345678 ↓↓↓↓↑↑x	43 5.12 mV/V 12345678 ↑↑↓↓↑↑x	44 5.34 mV/V 12345678 ↓↓↓↓↑↑x
45 5.54 mV/V 12345678 ↑↓↓↓↑↑x	46 5.72 mV/V 12345678 ↓↓↓↓↑↑x	47 7.50 mV/V 12345678 ↑↓↑↑↑↓x	48 10.50 mV/V 12345678 ↓↓↑↑↑↓x
49 13.20 mV/V 12345678 ↑↑↓↑↑↓x	50 15.60 mV/V 12345678 ↓↑↓↑↑↓x	51 17.80 mV/V 12345678 ↑↓↓↑↑↓x	52 19.70 mV/V 12345678 ↓↓↓↑↑↓x
53 21.50 mV/V 12345678 ↑↑↑↓↑↓x	54 23.10 mV/V 12345678 ↓↑↑↓↑↓x	55 24.60 mV/V 12345678 ↑↓↑↓↑↓x	56 25.90 mV/V 12345678 ↓↓↓↑↑↓x
57 27.10 mV/V 12345678 ↑↑↓↓↑↓x	58 28.30 mV/V 12345678 ↓↑↓↓↑↓x	59 29.30 mV/V 12345678 ↑↓↓↓↑↓x	60 30.30 mV/V 12345678 ↓↓↓↓↑↓x

Span (Gain) Setting Switch 1

Example :-

A strain gauge has a sensitivity of 2.809 mV /V - Select table 28 and fine tune with potentiometer P1

Table 3.7

SW1	1	2	3	4	5	6	7	8
2.63 mV/V	0 ↓	1 ↑	1 ↑	0 ↓	0 ↓	0 ↓	0 ↓	X



Refer to the Calibration Chapter 4 & Table 3.5

Zero (Offset) Setting Switch 2

This offset can be used to compensate for the transducer zero error, to tare the scale dead load or to shift the output.

These settings allow the user to calibrate a zero offset. The range allows for up to 79% of the span.

Use the fine adjustment is provided by potentiometer P2

Table 3.8

SW2	1	2	3	4	5	6	7	8
%	+ ve Offset	- ve Offset	40%	20%	10%	5%	2%	1%

Example :-

An installation has a tare of 15 kg with the 200kg strain gauge giving an output of 6.37mV/V at 10V excitation.

(The SGA excitation voltage is 10 V DC)

This equates to 15/200 =7.5% set switches to nearest % and adjust with Potentiometer P2.

The tare must be subtracted therefore the '- offset' switch SW2/2 should be 'ON'.

The calibrated zero mV reading would be 4.78 mV i.e. 7.5% of 63.7mV

Table 3.9

SW2	1	2	3	4	5	6	7	8
7.5%	0 ↓	1 ↑	0 ↓	0 ↓	0 ↓	0 ↑	0 ↑	0 ↓

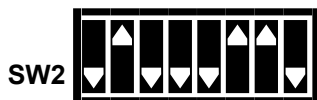

NOTE SW2 /1 & 2 should never be set 'ON ' together. Either one or other should be set 'ON ' if an offset is required; otherwise both switches should be set 'OFF '.

Switch settings 3 to 8 are ADDITIVE. The offset value of each switch is added to give a total offset of 79%.

Fine adjustment is provided by potentiometer P2.

Chapter 4 Calibration

The SGA/A & SGA/D provides the excitation supply and signal conditioning to cater for a wide range of strain gauges, load cells, pressure transducers or torque transducers.

Output

Select the analogue output range as detailed in Chapter 3, Figure 3.1, Table 3.1 & 3.2 by means of SW4.

Zero Offset

Select the offset as detailed in Chapter 3, Table 3.8 by means of SW2.

Having selected the polarity and the offset nearest to that required with the switches use the fine potentiometer P2 to achieve the final setting.

Sensitivity

Select the sensitivity as detailed in Chapter 3, Table 3.6 by means of SW1.

Switches 1-4 of SW1 provide fine setting of the SGA sensitivity while switches 5-7 give coarse control.

This arrangement allows the SGA to cover a wide range of strain gauge sensitivities without sacrificing stability and ease of set up.

Locate the required sensitivity in the table and set switches 1-7 of SW1 accordingly.

Potentiometer PI provides fine trimming and range overlap to enable the SGA to be calibrated precisely to any given value within its ranges.

NOTE 1 *If the range is repeated in the table e.g. 4mV/V (4.0, 4.05 and 4.0 mV/V) choose the setting which has the greatest number of switches 1-4 set to 'off' i.e. SW1 = [1000] [000]. This will enable finer trimming to the final value using potentiometer PI.*

The sensitivity settings shown in Table 3.6 assume that the load cell is fully loaded. The sensitivity settings can be used to maximise the output when the full range of the load cell is not being used. Here are a couple of examples.

Example 1 A 2.5mV/V loadcell provides 10V for an 100lb load. However it is never loaded above 50lb

The sensitivity setting can be set to 1.25 mV/V.

Table 3.5 /20 (1.20mV/V SW1 = [1101][000])

Example 2 *When a reduced output is required from a fully loaded transducer, use a less sensitive switch setting.*

For an 8 volt output from a fully loaded 2.5mV/V load cell use the 3.19mV/V setting i.e. (10/8x2.5=3.125mV/V)

Table 3.6 /31 (1.20mV/V SW1 = [0010][000])

The SGA/A & SGA/D can be calibrated with the transducer connected, provided that two calibration points can be implemented. e.g. by applying known weights or forces. If this is not possible, a stable mV source or load cell simulator can be used provided that the precise sensitivity (mV/V) and full range output (kg) of the transducer is known. In this case the 'Ref (5V)' output should be connected to 'strain input-' and the mV source applied between 'strain input+' and 'strain input-'.

Actual calibration is carried out in the following way:-

1. Set the correct switch settings on SW1 as described above using the transducer's calibration sheet supplied by the manufacturer. This is normally specified as sensitivity or full range output and should be in mV/V
2. Apply the known low calibration conditions (weight, force or mV/V : this may be zero if required), and note the analogue output, having ensured that the SW1 settings are correct for the transducer sensitivity as step 1 above.
3. Apply the known high calibration conditions (for optimum accuracy this should be at least 75% of full load) and note the analogue output.
4. Use the fine trim control, P1, to obtain the required change in Volts or mA, between the two calibration points (steps 2 and 3). e.g. If the required output at the low calibration point is 0V and the required output at the high calibration point is 7.5V, adjust P1 in step 4 to produce a change of 7.5V between the calibration points. Initially, the low calibration point may not produce 0V at the output. If this is the case, note the reading, e.g. 0.5V, apply the high calibration conditions and trim P1 for the required change in output. i.e. Trim the output for $0.5 + 7.5 = 8V$.
5. Use the fine 'Zero' control, P2 in conjunction with the coarse switches SW2/3-8 and polarity switches SW2/1 and 2 to set the output to the required absolute values. Each switch within SW2 offsets the output by a particular percentage of full scale as shown in Table 3.8

N.B. It may be necessary to repeat these steps until the required output is achieved.

Figure 4.1 Calibration Connections using Millivolt Source

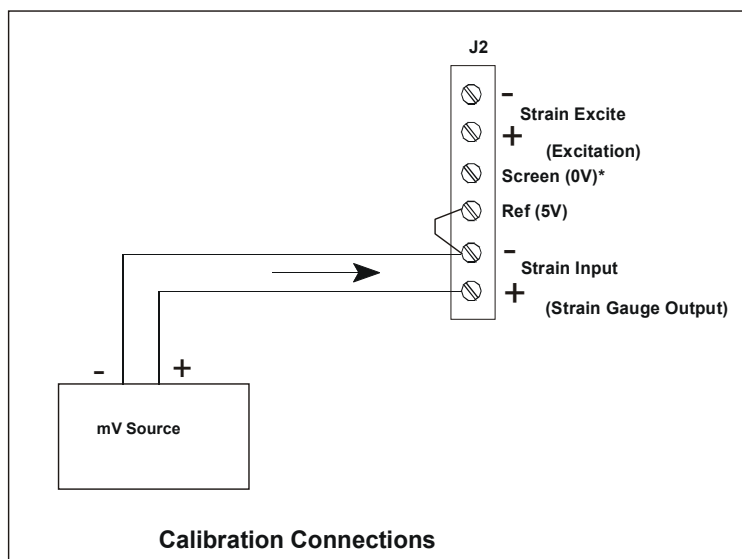

1. The 'Ref (5V)' should be connected to 'strain input-' and the mV source applied between 'strain input+' & 'strain input-'
2. Set the correct switch settings on SW1 as described above using the transducer's calibration sheet supplied by the manufacturer. This is normally specified as sensitivity or full range output and should be in mV/V
3. Ensure the Zero and Span switch settings are correct, as detailed in Chapter 3, Tables 3.6 & 3.8
4. Apply the known **low** calibration conditions and fine adjust P2.
5. Apply the known **high** calibration conditions and fine adjust P1
6. Repeat steps 3 and 4 until the required output is achieved.

Hint *If the required output at the low calibration point is 0V and the required output at the high calibration point is 7.5V, adjust P1 in step 5 to produce a change of 7.5V between the calibration points. Initially, the low calibration point may not produce 0V at the output. If this is the case, note the reading, e.g. 0.5V, apply the high calibration conditions and trim P1 for the required change in output, i.e. Trim the output for 0.5 + 7.5 = 8V.*

Chapter 5 Troubleshooting

1. No output

- a) Check power supply is present (LED is on).
- b) Check the output connections are correct.
- c) Check terminations (ensure insulation is not trapped in terminal, cable break etc.)
- d) Check the sensor is connected (typically reading 350 Ohm across output + & - of J2) with the power off.
- e) Check the Excitation voltage (J2) is at 10V DC

1.a For voltage output

- a) Check V out+ and V out- terminals are wired
- b) Check the load is connected and is not open or short circuited
- c) Check SW4 settings are correct for Voltage Output see Chapter 3, Table 3.2
- d) Check Span and Zero settings (SW1 and SW2)

1.b For current output

- a) Check Iout+ and Iout- terminals are used for 'Sink' current output
- b) Check Iout- and Vout- terminals are used for 'Source' current output.
- c) Check the load is connected and is not open circuit
- d) Check load does not exceed 500 Ohms.
- e) In 'Sink' mode check 15 V is present at +ve terminal of load.
- f) In 'Sink' mode check the 0V is connected to ground.
- g) In 'Sink' mode check the load is isolated from the load cell (sensor) excitation.
- h) In 'Source' mode check the -ve output is common to the -ve Excitation.
- i) Check output SW 4 settings are correct for current see Chapter 3, Table 3.2
- j) Check Span and Zero settings (SW1 and SW2) see Chapter 3, Table 3.6 & 3.8

2. Low Output

This is when an output is present but not of sufficient magnitude to meet the required value.

- b) Check power supply is within specified limits (i.e. is not low)
- c) Check the sensor is connected (typically reading 350 Ohm across output + & - of J2) with the power off.
- d) Check the Excitation voltage (J2) is at 10V DC
- e) Check the calibration. Incorrect setting of the calibration Span switches are the most common cause of low output - particularly when associated with \pm Voltage outputs. Refer to the calibration instructions in Chapter 4. Refer to tutorial on the calibration set-up.
- f) Check the Zero (offset) is correct for the sensor. This too is a common reason for low outputs.

3. High output

This is when an output is present but higher (in span or zero) than required.

- b) Check the sensor is connected (typically reading 350 Ohm across output + & - of J2) with the power off.
- c) Check the Excitation voltage (J2) is at 10V DC
- d) Check the Zero (offset) is correct for the sensor. This is a common reason for high outputs where the offset is either omitted or incorrect for the sensor. Refer to the calibration instructions in Chapter 4
- e) Refer to tutorial on the calibration set-up
- f) Check the calibration. Incorrect setting of the calibration span switches is the most common cause of low output - particularly when associated with \pm Voltage outputs.

4. Unstable Output

This is when the output is unstable or varies. The cause could be (a) poor installation or (b) a noisy environment.

Poor Installation -This is when an output is present but higher or lower (in span or zero) than expected:

- a) Check the installation for problems and repair where necessary
- b) Poor termination
- c) High resistance on cable leads
- d) Low insulation impedance
- e) Proximity to High Voltage Equipment – Transformers, Contactors, Motors etc.

Noisy Environment-

- a) Check if the source can be found and remove noise
- b) Check the cable screening and ensure it is correctly installed and terminated

5. Calibration

This section assumes that the unit is providing an output that is not stuck at top or bottom of the scale.

(See paragraphs 1 to 4 if this is the case)

Ensure you have the calibration set-up correctly installed i.e.mV source and output as required.

Ensure you are connected to the correct sensor and not to another adjacent unit.

Ensure you have the correct calibration data from the sensor manufacturer. This must include a certified table with offset, zero and linearity.

Ensure the temperature and other environmental parameters are within specification and where necessary taken into account when calibrating should such parameters have an effect on the calibration.

6. Fine Span (Gain) and Zero (Offset) Adjustment Problems

If the adjustment cannot reach the maximum output desired then, check the tare is not too high.

If the potentiometer does not alter the output the unit must be repaired – remove from service. It is always wise to check a known good SGA against the problem installation before rejecting the suspect SGA.

Chapter 6 Product Care

A worn out component, excessive use in harsh environments, an overly zealous operator; regrettably some circumstances necessitate repair.

At Mantracourt Electronics Ltd we can't guarantee that a product will never require repairing. We can, however, promise a repair service of exceptional quality, one which is governed by a rigorous procedure.

Detailed below is our pledge to you: a defined set of ground rules and procedures to which we will adhere. All we ask in return is that you assist us with our procedure, such that we can maintain our promise to you. Please note that warranty repairs may not be available on overdue accounts, and that a strict interpretation of our conditions of trading invalidates warranty claims where late payment has occurred.

Please refer to 'Customer Repair Service Procedure' document – contact your supplier for a copy.

In the unlikely event you have problems with the SGA module we would advise that you take the following precautions:-

- The unit is installed as instructed.
- Recommended spares are kept in stock. We can assist.
- Sufficient expertise available for first line maintenance.
- Routine maintenance checks are performed – annually is recommended.
- The necessary documentation for the product is available to the maintenance personnel.

We recommend you keep on file – as a minimum

- This Manual
- The settings of the switches and links on the SGA card
- The calibration figures for the attached sensors
- The instrument loop to which the output is connected
- A record of the 'normal' output – if applicable
- A maintenance record of the SGA
- A contact phone number from the supplier for assistance

Chapter 7 Glossary

AWG	American Wire Gauge.
Background Noise	The total noise floor from all sources of interference in a measurement system, independent of the presence of a data signal. (See noise)
Bipolar	The ability of a signal conditioner to display either positive or negative readings.
Bridge Resistance	The resistance measured across the excitation terminals of a strain gauge.
Calibration	The process of adjusting an instrument or compiling a deviation chart so that it's reading can be correlated to the actual value being measured.
CMR (Common-Mode Rejection)	The ability of an instrument to eliminate the effect of AC or DC noise between signal and ground. Normally expressed in dB at dc to 60 Hz. One type of CMR is specified between SIG LO and PWR GND. In differential meters, a second type of CMR is specified between SIG LO and ANA GND (METER GND).
Common Mode Rejection Ratio	The ability of an instrument to reject interference from a common voltage at its input terminals with relation to ground. Usually expressed in db (decibels).
Deadband / hysteresis	(Hysteresis) In a digital controller, there may be one switching point at which the signal increases and another switching point at which the signal decreases. The difference between the two switching points is hysteresis.
Drift	A change of a reading or a set point value over long periods due to several factors including change in ambient temperature, time, and line voltage.
Dual Power supply	The SGA/A can have a Dual Power Supply. An AC supply can be connected along with a DC supply for additional security.
Excitation	The external application of electrical voltage applied to a transducer for normal operation.
Fine Adjustment	The Zero and Span calibration have a Fine Adjustment to give accuracy to the calibration. These are potentiometers P1 and P2 for span and zero respectively.
Full Bridge	A Wheatstone bridge configuration utilizing four active elements or strain gauges.
Full Range Output	The algebraic difference between the minimum output and maximum output.
Gain	Gain is otherwise identified as SPAN. It relates to the proportional output to the sensor input. Calibration of the SGA is determined by setting the Gain (Span) and Offset (Zero). The amount of amplification used in an electrical circuit.
Ground/Earth	1)The electrical neutral line having the same potential as the surrounding earth. 2) The negative side of power supply. 3) Reference point for an electrical system.
Input Impedance	The resistance measured across the excitation terminals of a transducer.
Linearity	The closeness of a calibration curve to a specified straight line. Linearity is expressed as the maximum deviation of any calibration point on a specified straight line during any one calibration cycle.
Load	The electrical demand of a process expressed as power (watts), current (amps) or resistance (ohms).
Load Impedance	The impedance presented to the output terminals of a transducer by the associated external circuitry.
Load cell	The load cell is one of a series of Strain Gauge sensors that the SGA input is designed to accept. (Torque Sensor, Pressure & temperature transducers).
Low Pass Filter	The SGA Module has a low pass filter to remove unwanted signals on the output. This can be set to suit the installation, from DC to 5kHz.
Millivolt	One thousandth of a volt, 10^{-3} volts symbol mV.

NEMA 4/ UL Type 4	A standard from the National Electrical Manufacturers Association, which defines enclosures, intended for indoor or outdoor use primarily to provide a degree of protection against windblown dust and rain, splashing water, and hose-directed water.
Noise	An unwanted electrical interference on the signal wires.
Null	A condition, such as balance, which results in a minimum absolute value of output.
Offset	Offset is otherwise identified as Zero. It relates to the proportional output to the sensor input. Calibration of the SGA is determined by setting the Offset (Zero) and Gain (Span).
Potentiometer	Two potentiometers (variable resistors) are used in the SGA for fine calibration.
Pressure Transducer	The Pressure Transducer is one of a series of Strain Gauge sensors that the SGA input is designed to accept. (Torque Sensor, Load Cell and Temperature transducers).
Proportional Outputs	The Voltage or Current outputs are calibrated to be directly proportional to the input from the sensor. The output is, within the sensor limits, taken as linear and no linearity compensation is required within the SGA.
Resolution	The input corresponding to a one-unit change in the least significant digit of the data acquisition /display equipment (Good resolution is not necessarily equal to good accuracy.)
Sensing Element	That part of the transducer, which reacts directly in response to the input.
Sensitivity	The minimum change in input signal to which an instrument can respond. This is the relationship between the change in strain gauge output to the level or magnitude of the SGA output
Signal Conditioner	A circuit module that offsets attenuates, amplifies, linearizes and/or filters the signal for input to an A/D converter. A typical output signal conditioning is 4 to 20 mA. The SGA is essentially a Signal Conditioner –more specifically known as a Strain Gauge Amplifier - in that it <i>conditions</i> (alters) the input signal from a load cell to an electrical output
Single card assembly	The SGA has only the one Printed Circuit Board assembly on which all the components are mounted. The assembly is then mounted inside an environmentally rugged enclosure.
Span	Span is otherwise identified as GAIN. It relates to the proportional output to the sensor input. Calibration of the SGA is determined by setting the Span (Gain) and Zero (Offset).
Span Adjustment	The ability to adjust the gain of a process or strain meter so that a specified display span in engineering units corresponds to a specified signal span. For instance, a display span of 200°F may correspond to the 16 mA span of a 4-20 mA transmitter signal.
Stability	The quality of an instrument or sensor to maintain a consistent output when a constant input is applied.
Strain Gauge	The strain gauge is a resistance bridge device where the bridge value alters linearly and proportionally to the force exerted on it – be it temperature, pressure, torque or load. The SGA is designed to convert this change in the of the strain gauge to a proportional electrical signal.
Strain Gauge Amplifier	The SGA is essentially a type of Signal Conditioner that it conditions (alters) the input signal from a strain gauge to an electrical output
Torque Transducer	The Torque Transducer is one of a series of STRAIN GAUGE sensors that the SGA input is designed to accept. (Torque Sensor, Load Cell and Temperature transducers).
Zero	Zero is otherwise identified as Offset. It relates to the proportional output to the sensor input. Calibration of the SGA is determined by setting the Span (Gain) and Zero (Offset).
Zero Adjustment	The ability to adjust the display of a process or strain meter so that zero on the display corresponds to a non-zero signal, such as 4 mA, 10 mA, or 1 V dc.

Zero Offset	The difference expressed in degrees between true zero and an indication given by a measuring instrument. See Zero Suppression
Zero Suppression	The span of the SGA can be offset from zero (zero suppressed) such that neither limit of the span will be zero. For example, an SGA which measures a load of a 100kg span from 400kg to 500kg° is said to have 400kG zero suppression.

AC	Alternating Current
DC	Direct Current
Hz	Hertz (Frequency)
IP66	UK Environmental Specification
kHz	kilohertz (Frequency)
mA	milliamps
mm	millimetres
NEMA 4X	US Environmental Specification
SC	Signal Conditioner
SGA	Strain Gauge Amplifier
V	Volts
mV	millivolts

Chapter 8 Specifications for SGA/A & SGA/D Load Cell Amplifiers

Parameter	Min	Typical	Max	Units
Power supply (SGA/A):- (110/230Vac) 50 - 60Hz	-	110/230	-	V AC
Power supply dc: -	18	-	24*	V DC
Power supply current dc: - (depends on loading)	50	90	200	mA
Bridge excitation 350R Strain Gauge	9.5	10	10.5	V
Bridge resistance	85	-	-	Ohms
Bridge sensitivity (Switchable)	0.06	-	29	mV/V
Gain adjustment (Pot - fine adj.)	0.06	-	1.0	mV/V
Offset adjustment (Pot - fine adj.)	0	-	±1.25	%FR
Offset adjustment (Switchable - coarse adj)	±1.25	-	±79	%FR
Output load (Voltage output)	-	-	2	mA
Output load (Current output)	0	-	500	Ohms
Bandwidth (No filter and > 2mV/V)	DC	-	6	kHz
Filter cut-off (Switchable ranges)	1	-	5000	Hz
Zero temperature coefficient (@2.5mV/V)	-	0.002	0.009	%/°C@ 2.5mV/V FR
Span temperature coefficient	-	0.007	0.01	%/°C
Linearity	-	0.03	-	%FR
Gain stability -1st 1000 Hours	-	0.2	-	%FR
Gain stability - 2nd 1000 Hours	-	0.1	-	%FR
90 day Offset stability	-	3.3	-	uV
Output load stability gain (0 - 100%)	-	-	0.01	%FR
Output load stability offset (0 - 100%)	-	-	0.01	%FR
Power supply rejection gain (0 - 100%)	-	-	0.01	%FR
Power supply rejection offset (0 - 100%)	-	-	0.01	%FR
Operating temperature range	-10	-	50	°C
Storage temperature range	-20	-	70	°C
Humidity	-	-	95	%

*N.B. 18V max at full load

Output options:

±10V, ±5V, 0-10V, 0-5V, 0-20mA, 4-20mA

Connections:

Field screw terminals - 2.5mm² rising clamp.

Enclosure:

ABS case 160 x 80 x 55 sealed to IP65 fitted with 3 off cable glands.

Controls:

Gain pot
Offset pot
Coarse gain switches
Coarse offset switches
Filter cut-off switches
Output mode switch

Environmental Approvals

EMC Emissions	EN 50 081-1	:1992 (Light industrial)
EMC Emissions	EN 50 081-2	:1992 (Heavy industrial)
EMC Immunity	EN 50 082-1	:1992 (Light industrial)
(RF Field Test 100 ppm of reading over 30 to 500MHz)	EN 50 082-2	:1992 (Heavy industrial)
(RF Field Test 500 ppm of reading over 30 to 500MHz)		
Low Directive	IEC 1010, EN 61010	

WARRANTY

All SGA products from Mantracourt Electronics Ltd., ('Mantracourt') are warranted against defective material and workmanship for a period of (3) three years from the date of dispatch. If the 'Mantracourt' product you purchase appears to have a defect in material or workmanship or fails during normal use within the period, please contact your Distributor, who will assist you in resolving the problem. If it is necessary to return the product to 'Mantracourt' please include a note stating name, company, address, phone number and a detailed description of the problem. Also, please indicate if it is a warranty repair. The sender is responsible for shipping charges, freight insurance and proper packaging to prevent breakage in transit.

'Mantracourt' warranty does not apply to defects resulting from action of the buyer such as mishandling, improper interfacing, operation outside of design limits, improper repair or unauthorised modification.

No other warranties are expressed or implied. 'Mantracourt' specifically disclaims any implied warranties of merchantability or fitness for a specific purpose. The remedies outlined above are the buyer's only remedies. 'Mantracourt' will not be liable for direct, indirect, special, incidental or consequential damages whether based on the contract, tort or other legal theory.

Any corrective maintenance required after the warranty period should be performed by 'Mantracourt' approved personnel only.

Figure 8.1 Connection Details

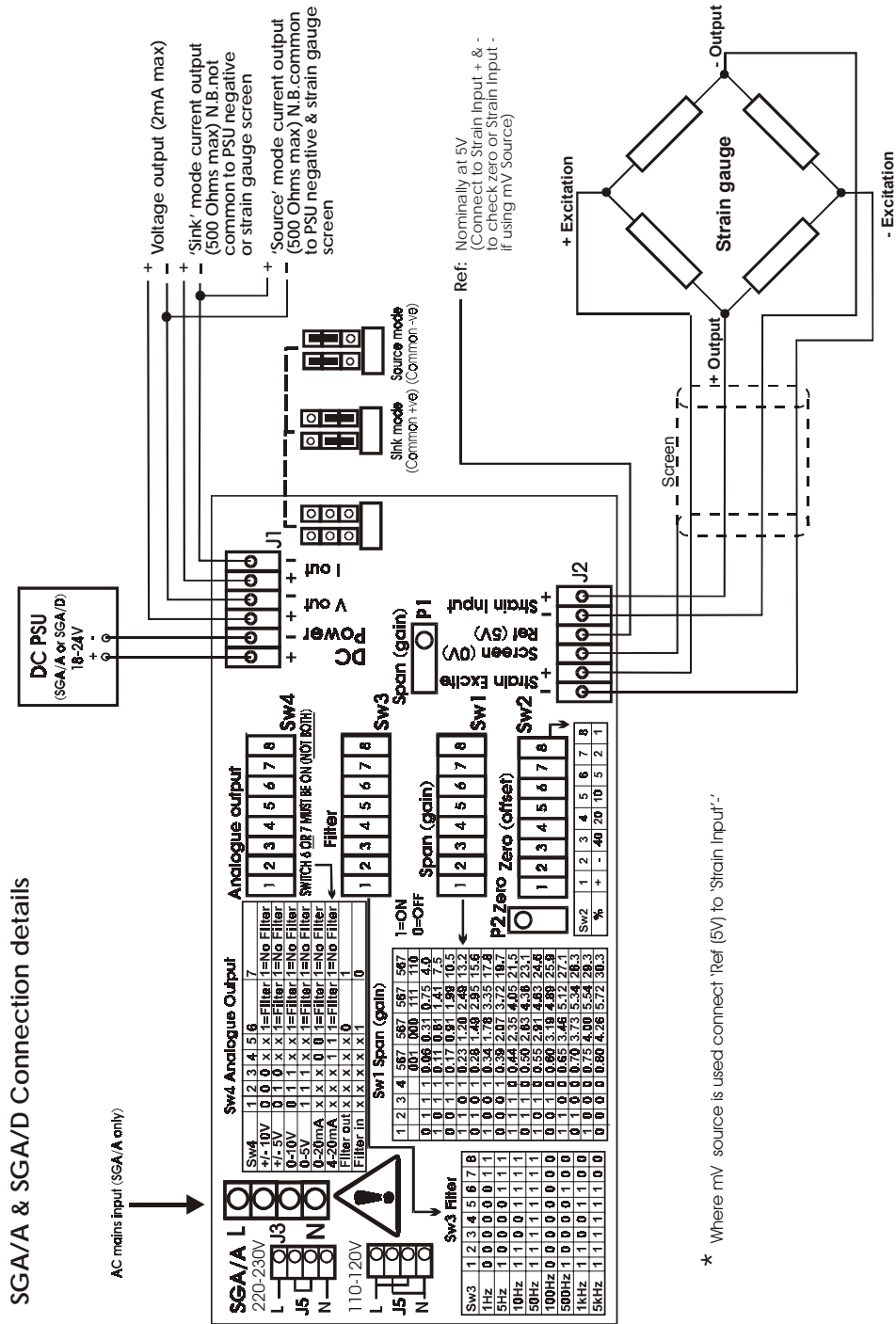



In the interests of continued product development, Mantracourt Electronics Limited reserves the right to alter product specifications without prior notice.

Other Mantracourt Products

www.mantracourt.co.uk

Signal Conditioning

<p>SGA STRAIN GAUGE AMPLIFIER</p> <p>Connect up to 4 strain gauges Proportional mA and/or Voltage output Simple DIL switch configuration Set Sensitivity and Low pass filter and output Simple - Reliable - Rugged</p>	<p>ICA IN-CELL STRAIN GAUGE AMPLIFIER</p> <p>Proportional mA or Voltage output Single strain gauge applications small in size – Big on Specification</p>
<p>LCA IN-LINE INTELLIGENT STRAIN GAUGE AMPLIFIER</p> <p>2 Set Points 4 to 20 mA AND 0 to 10 V (isolated) outputs RS 232/485 Communications port On-Board easy to use Programmer Auto tare – Auto calibrate – and much more</p>	<p>ADW15 72 mm DIN Module – Display & Controller</p> <p>10 mm LED Display (Configurable) Sensitivity from 0.5 mV to 200 mV/V 10 V @150 mA Excitation Isolated I/O100mSec sample rate Set Point Relays 4 to 20 mA Output Programmable via keypad</p>
<p>FIELDBUS CONNECTIVITY IN TWO EXCELLENT PACKAGES</p>	
<p>DSC The Digital Strain Card</p>	<p>'D'Cell The 'in-cell' Digital Strain Puck</p>
	
<p>Mount this package adjacent to the strain gauge</p>	<p>Mount this package directly into the strain gauge pocket</p>
<p>Plug-in-and-go-sensor</p>	<p>High accuracy</p>
<p>Integrate the electronics with the load cell, remove the cost, space and bother of additional electronics and have a direct output provided in REAL ENGINEERING UNITS.</p>	<p>A quantum leap in the quality of measurement.</p>
	<p>Accuracy (1 part in half a million) Temperature compensated Unwanted Signal noise filter Sensor specific calibration Elimination induced noise on signals</p>