

# ICA3

## Miniature In Cell Amplifier for Strain Gauges



[www.mantracourt.co.uk](http://www.mantracourt.co.uk)

User Manual Instructions

**ME** **MANTRACOURT**  
ELECTRONICS LIMITED

## ICA3 Manual

### Contents

<b>Chapter 1 Introduction to ICA3 .....</b>	<b>2</b>
Figure 1.1 Block Diagram .....	2
<b>Chapter 2 Installing the ICA3 .....</b>	<b>3</b>
Pre Installation.....	3
Figure 2.1 Dimensions .....	3
Power Connections .....	4
Figure 2.2 Connection Details for the ICA3.....	4
Figure 2.3 Connection Details for Best EMC Immunity.....	4
Table 2.1.....	5
Output connections .....	5
<b>Chapter 3 Setting Gain Resistor .....</b>	<b>6</b>
Table 3.1 ICA3 ( $\pm 10$ Volts).....	6
<b>Chapter 4 Calibration .....</b>	<b>7</b>
Figure 4.1 Connection Details for Calibration .....	7
<b>Chapter 5 Troubleshooting.....</b>	<b>8</b>
<b>Chapter 6 Product Care .....</b>	<b>10</b>
<b>Chapter 7 Glossary.....</b>	<b>11</b>
<b>Chapter 8 Specifications for ICA3 Load Cell Amplifiers .....</b>	<b>13</b>
Table 8.1 ICA3 – $\pm 10$ Volts DC Output .....	13
Environmental Approvals .....	13
<b>Other Mantracourt Products.....</b>	<b>14</b>

## Chapter 1 Introduction to ICA3

**Figure 1.1 Block Diagram**

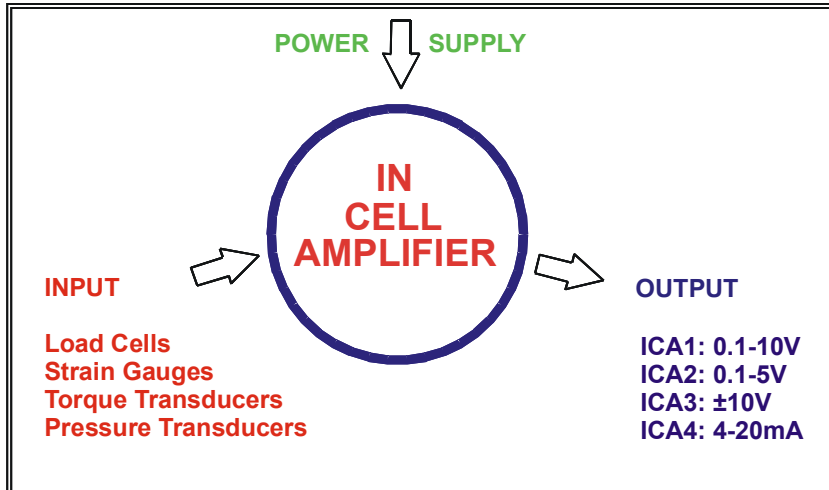

The ICA is a Strain Gauge Amplifier, converting a Strain Gauge input to a Volt or mA output – otherwise known as a Signal Conditioner.

The ICA provides a wide range of signal conditioning for Strain Gauges, Load Cells, Pressure and Torque Transducers.

Offered in 4 versions

- ICA1 - 3 wire - 0.1 to 10 volts
- ICA2 - 3 wire - 0.1 to 5 volts
- ICA3 - 4 wire -  $\pm 10$  volts
- ICA4 - 3 wire - 4 to 20 mA

This manual only deals with Version ICA3, separate manuals exist for versions ICA1 & 2 and the ICA4.

Transducer **SENSITIVITY** of between 0.5 mV/V and 30mV/V are possible. It is optimised to 2.5 mV/V. This range covers most - but not all – strain gauges.

Sensitivity adjustment is achieved by a combination of gain (span) resistor 'R' change and associated *fine adjustment* by potentiometer.

Similarly transducer **ZERO** can be compensated for in the module. This adjustment is to compensate for slight errors in the strain gauge and not to offset tare.

Mantracourt's SGA (Strain Gauge Amplifier) covers a range from 0.06 mV/V to 30mV/V and it's 79% offset can provide tare compensation.

## Chapter 2 Installing the ICA3

### **Pre Installation**

See Specification Details in Chapter 8 for details of Environmental Approvals.

Carefully remove the ICA unit from its shipment box. Check that the unit is complete and undamaged.

**Check The Model: Type (1,2,3 or 4) – they look similar.**

The ICA units can be operated in any industrial environment providing the following limits are not exceeded

Operating Temperature	-40°C to +85°C
Humidity	95% non condensing
Storage temperature	-40°C to +85°C

The following installation practices are advised:

- Minimise vibration
- Do not mount next to strong electrical fields (transformers, power cables)
- Ensure easy access to the module
- Install electrical protection device as the unit is not internally fused
- Always ensure the package is secure and protected

**Figure 2.1 Dimensions**

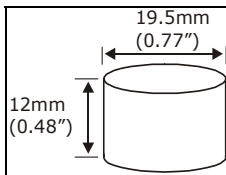

The module is designed to fit in the strain gauge pocket. Use the 2.5mm hole to secure the unit if required.

Take care soldering cables to the pads. Use a temperature controlled soldering iron set to a maximum 330°C, for no longer than 2 seconds per pad. Excessive heat or increased soldering time may result in damage to the PCB.

**If changing resistor 'R' do so at a workbench and not on site.**

Check the relevant details for model ICA3 – ensure the module matches the instructions:

The ICA 3 solder pads are as shown  
 4 pads for the strain gauge  
 3 pads are for power supply ( +ve, -ve and Common- common linked to earth)  
 2 pads for the output

**Power Connections**

The power supply for the ICA3 is  $\pm 14V$  dc within the limits of  $\pm 13V$  to  $\pm 15V$ . The power supply is linked to the Strain Gauge chassis via a series Capacitor.

**Figure 2.2 Connection Details for the ICA3**

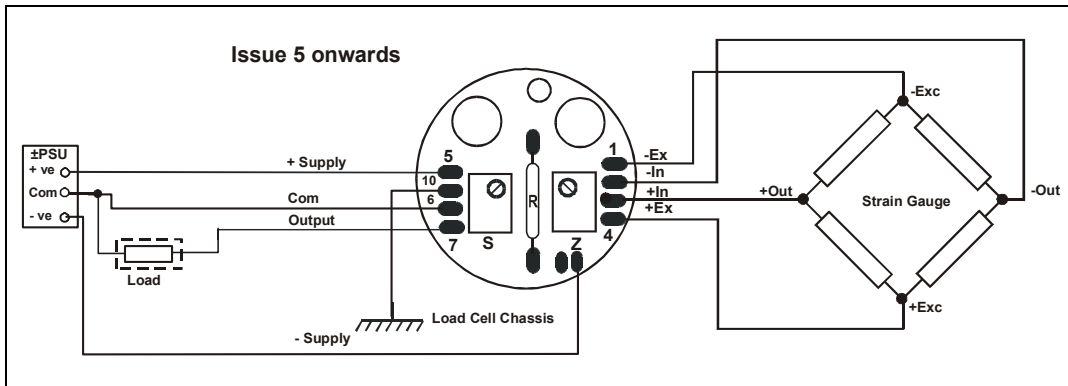

The strain gauge cable should be attached to the solder pads as illustrated  
 As illustrated, for most applications 3 wire un-screened connections are quite adequate.

For best EMC performance use the connections shown in Figure 2.3

**Figure 2.3 Connection Details for Best EMC Immunity**

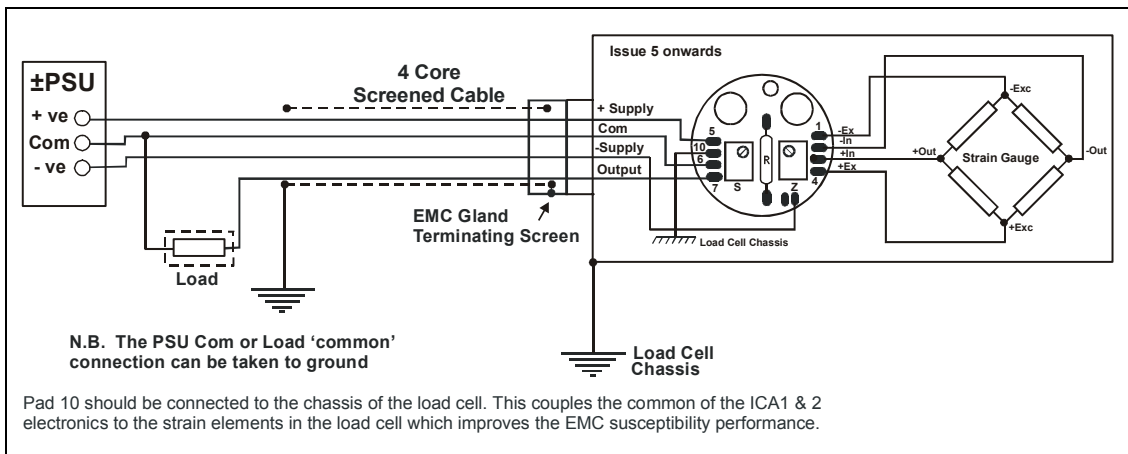

Take note of the earthing arrangement particularly pad 10 which capacitively couples the common of the ICA electronics to the strain elements in the load cell which improve the EMC performance.

This connection should be made with 7/0.2 minimum cable with a maximum length of 12 mm (0.5")

This typical cable data is provided for information only.

The cable should have 2 x twin twisted cables. Ideally with each pair individually screened and with an overall screen.

**Table 2.1**

Country	Supplier	Part No	Description
UK	Farnell	148-539	Individually screened twisted multipair cable (7/0.25mm)- 2 pair Tinned copper drain. Individually screened in polyester tape. Diameter: 4.19 mm Impedance: 54 Ohms: Capacitance/m: core to core 115 pF & core to screen 203 pF
UK	Farnell	585-646	Individually screened twisted multipair cable (7/0.25mm)- 3 pair Tinned copper drain. Individually screened in polyester tape. Diameter: 6.86 mm Impedance: 62 Ohms: Capacitance/m: core to core 98 pF & core to screen 180 pF
UK	RS	367-533	Braided screened twisted multipair cable (7/0.2mm)- 1 pair Miniature- twin -round Diameter: 4.8 mm Impedance: 62 Ohms: Capacitance/m: core to core 120 pF & core to screen 210 pF

If possible segregate the signal cable from Power Cables; allow a 1 metre (3 foot) distance from such cables.

Do not run signal cable in parallel with power cables and cross such cables at right angles.

The earth connection conductor should have sufficient cross-sectional area to ensure a low impedance path to attenuate RF interference.

### **Output connections**

The ICA3 provides an output of  $\pm 10V$ . Other bi-polar outputs can be configured by altering Resistor R.

While they utilize the same pcb they have different components on board.

Connect the Output as shown in Figure 2.2 or alternatively Figure 2.3

## Chapter 3 Setting Gain Resistor

The ICA3 is a +/- 10V Strain Gauge Amplifier.

They are supplied un-calibrated but optimized for a sensitivity of 2.5mV/V. To accommodate other sensitivities the gain resistor 'R' as shown in Figure 2.2, can be changed according to the following formula.

N.B. a high quality component (e.g. 1% 50 ppm metal film device) should be used for optimum performance. It may be necessary to use an E96 value for optimum trim range:-

**Table 3.1 ICA3 ( $\pm 10$  Volts)**

Gain =	$\frac{155}{(\text{required mV/V})}$		R =	$\frac{24,000}{(\text{Gain}-1)}$ Ohms
e.g.1	For 2.5 mV/V (Factory setting):-	Gain = 62x	R = 393 Ohms	(Used preferred value 390R)
e.g.2	For 0.5 mV/V	Gain = 310x	R = 78 Ohms	(Used preferred value 75R)
e.g.3	For 5.0 mV/V	Gain = 31x	R = 800 Ohms	(Used preferred value 820R)

N.B If an output other than  $\pm 10$ V is required e.g.  $\pm 5$ V then reduce the gain calculation in proportion i.e. for  $\pm 5$  Volt

Gain =	$\frac{155}{(\text{required mV/V})} \times \frac{5}{10}$		R =	$\frac{24,000}{(\text{Gain}-1)}$ Ohms
e.g.1	For 2.5 mV/V (Factory setting):-	Gain = 31x	R = 800 Ohms	(Used preferred value 820R)

## Chapter 4 Calibration

The ICA3 can be calibrated with the transducer connected provided that two calibration points can be implemented e.g. by applying known weights or forces. If this is not possible, a stable mV source or load cell simulator can be used if the precise sensitivity (mV/V) of the transducer is known.

**Figure 4.1 Connection Details for Calibration**

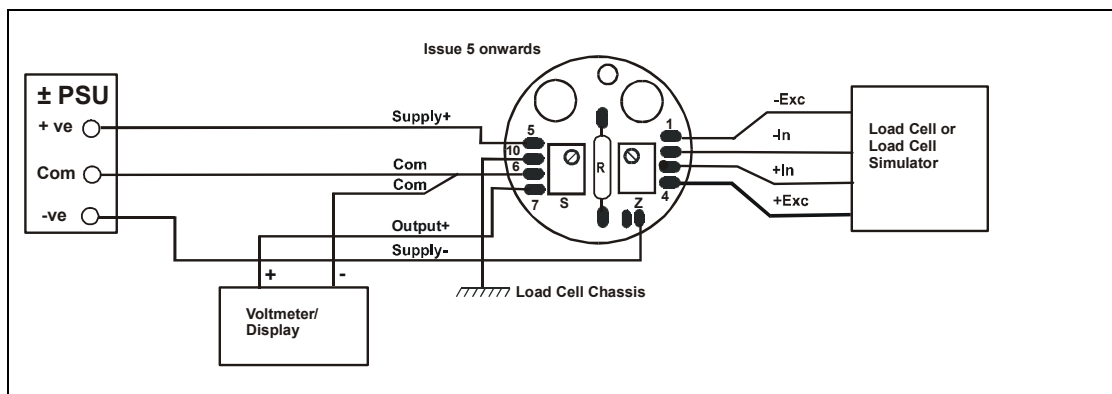

- 1) Apply the zero calibration conditions (weight, force or mV/V). Set the output to approx. 0V using the 'Z' potentiometer and note the exact reading.
- 2) Apply the known high calibration conditions (ideally between 75% and full scale) and adjust the 'S' potentiometer to give the required change in output voltage for the known input (e.g. 10V change for 0 - 10V final calibration).
- 3) Apply the zero calibration conditions again and note the new value. Apply the high conditions and re-adjust the 'S' pot. for the required change.
- 4) Repeat steps 2) and 3) until the span is correct.
- 5) Apply the 'zero' calibration conditions and adjust the 'Z' pot. for a reading of 0V



## Chapter 5 Troubleshooting

### 1. No Output

- a) Check power supply is present and the correct polarity
- b) Check the output connections are correct with no open circuit connections
- c) Check terminations (ensure there are no dry joints)
- d) Check the sensor is connected (typically reading 350 Ohm across output + & -) with the power off
- e) Check the Excitation voltage is correct
- f) Check the load is connected and is not open or short circuited
- g) Check Span and Gain calibration

### 2. Low Output

This is when an output is present but not of sufficient magnitude to meet the required value. Remember to allow for Tare Weight and ensure it is measured and allowed for in the output from the ICA.

- a) Check power supply is within specified limits (i.e. is not low)
- b) Check the sensor is connected (typically reading 350 Ohm across output + & -) with the power off.
- c) Check the Excitation voltage is at 8V DC
- d) Check the calibration
- e) Check the Zero (offset) is correct for the sensor, this too is a common reason for low outputs

### 3. High Output

This is when an output is present but higher (in span or zero) than expected.

High output is not normally a problem. It is most likely to be incorrect connections and as such the output would be high and fixed

- a) Check the sensor is connected (typically reading 350 Ohm across output + & -) with the power off
- b) Check the Excitation voltage is at 8V DC
- c) Check the Zero (offset)
- d) Check the calibration.

### 4. Unstable Output

This is when the output is unstable or varies. The cause could be (a) poor installation or (b) a noisy environment.

**Poor Installation** - This is when an output is present but higher or lower (in span or zero) than expected:

- a) Check the installation for problems and repair where necessary
- b) Poor termination
- c) High resistance on cable leads
- d) Low insulation impedance
- e) Proximity to High Voltage Equipment – Transformers, Contactors, Motors etc.

**Noisy Environment-**

- a) Check if the source can be found and remove noise
- b) Check the cable screening and ensure it is correctly installed and terminated.

### 5. Calibration

This section assumes that the unit is providing an output that is not stuck at top or bottom of the scale.

(See paragraphs 1-3 if this is the case)

Ensure you are connected to the correct sensor and not to another adjacent unit.

Ensure you have the correct calibration data from the sensor manufacturer. This must include a certified table with offset, zero and linearity.

Ensure you have the calibration set-up correctly installed i.e.mV source and output as required.

Ensure the temperature and other environmental parameters are within specification and where necessary taken into account when calibrating should such parameters have an effect on the calibration.

**6. Fine Span (Gain) and Zero (Offset )Adjustment Problems**

If the adjustment cannot reach the maximum output desired then, check the tare is not too high.

If the potentiometer does not alter the output the unit must be repaired – remove from service. It is always wise to check a known good ICA against the problem Installation before rejecting the suspect ICA.

## Chapter 6 Product Care

A worn out component, excessive use in harsh environments, an overly zealous operator; regrettably some circumstances necessitate repair.

At Mantracourt Electronics Ltd we can't guarantee that a product will never require repairing. We can, however, promise a repair service of exceptional quality, one which is governed by a rigorous procedure.

Detailed below is our pledge to you: a defined set of ground rules and procedures to which we will adhere. All we ask in return is that you assist us with our procedure, such that we can maintain our promise to you. Please note that warranty repairs may not be available on overdue accounts, and that a strict interpretation of our conditions of trading invalidates warranty claims where late payment has occurred.

Please refer to 'Customer Repair Service Procedure' document – contact your supplier for a copy.

In the unlikely event you have problems with the ICA module we would advise that you take the following precautions:-

- The unit is installed as instructed.
- Recommended spares are kept in stock. We can assist.
- Sufficient expertise available for first line maintenance.
- Routine maintenance checks are performed – annually is recommended.
- The necessary documentation for the product is available to the maintenance personnel.

### **We recommend you keep on file – as a minimum**

- This Manual
- The calibration figures for the attached sensors
- A record of the 'normal' output – if applicable
- A calibration record of the ICA
- A contact phone number from the supplier for assistance

## Chapter 7 Glossary

AWG	American Wire Gauge.
Background Noise	The total noise floor from all sources of interference in a measurement system, independent of the presence of a data signal. (See Noise)
Bipolar	The ability of a signal conditioner to display both positive and negative readings.
Bridge Resistance	The resistance measured across the excitation terminals of a Strain Gauge.
Calibration	Adjustment of an instrument or compiling a deviation chart so that it's reading can be correlated to the actual value being measured.
CMR (Common-Mode Rejection)	The ability of an instrument to eliminate the effect of AC or DC noise between signal and ground. Normally expressed in dB at DC to 60 Hz. One type of CMR is specified between SIG LO and PWR GND. In differential meters, a second type of CMR is specified between SIG LO and ANA GND (METER GND).
Common Mode Rejection Ratio	The ability of an instrument to reject interference from a common voltage at its input terminals with relation to ground. Usually expressed in db (decibels).
Drift	Change of a reading/set point value over periods due to several factors including change in ambient temperature, time and line voltage.
Excitation	The external application of electrical voltage current applied to a transducer for normal operation.
Fine Adjustment	Zero and Span calibration have a Fine Adjustment to give accuracy to the calibration. These are potentiometers P1 and P2 for Span and Zero respectively.
Full Bridge	A Wheatstone Bridge configuration utilizing four active elements or Strain Gauges.
Full Range Output	The algebraic difference between the minimum output and maximum output.
Gain	Gain is otherwise identified as SPAN. It relates to the proportional output to the sensor input. Calibration of the ICA is determined by setting the Gain (Span) and Offset (Zero). The amount of amplification used in an electrical circuit.
Ground/Earth	The electrical neutral line having the same potential as the surrounding earth.
Linearity	The closeness of a calibration curve to a specified straight line. Linearity is expressed as the maximum deviation of any calibration point on a specified straight line during any one calibration cycle.
Load	The electrical demand of a process expressed as power (watts), current (amps) or resistance (ohms).
Load Impedance	The impedance presented to the output terminals of a transducer by the associated external circuitry.
Load Cell	The load cell is one of a series of STRAIN GAUGE sensors that the ICA input is designed to accept. (Torque Sensor, Pressure & temperature transducers).
Millivolt	One thousandth of a volt, $10^{-3}$ volts symbol mV.
Noise	An unwanted electrical interference on the signal wires.
Null	A condition, such as balance, which results in a minimum absolute value of output.
Offset	Offset is otherwise identified as ZERO. Calibration of the ICA is determined by setting the Offset (Zero) and Gain (Span).
Potentiometer	Two potentiometers (variable resistors) are used in the ICA for fine calibration.
Pressure Transducer	The Pressure Transducer is one of a series of Strain Gauge sensors that the ICA input is designed to accept. (Torque Sensor, Load Cell and Temperature Transducers).
Proportional Outputs	The Voltage or Current outputs are calibrated to be directly proportional to the input from the sensor. The output is, within the sensor limits, taken as linear and no linearity compensation is required within the ICA.
Resolution	The input corresponding to a one-unit change in the least significant digit of the data acquisition/display equipment. (Good resolution is not necessarily equal to good accuracy.)
Sensing Element	That part of the Transducer, which reacts directly in response to the input.
Sensitivity	This is the relationship between the change in Strain Gauge input to the level or magnitude of the output.

Signal Conditioner	A circuit module that offsets attenuates, amplifies linearizes and/or filters the signal. The ICA is essentially a Signal Conditioner –more specifically known as a Strain Gauge Amplifier - in that it CONDITIONS (alters) the input signal from a load cell to an electrical output.
Single Card Assembly	The ICA has only the one Printed Circuit Board assembly on which all the components are mounted. The assembly is then mounted inside an environmentally rugged enclosure.
Span	Span is otherwise identified as GAIN. It relates to the proportional output to the sensor input. Calibration of the ICA is determined by setting the Span (Gain) and Zero (Offset).
Span Adjustment	The ability to adjust the gain of a process or strain meter so that a specified display span in engineering units corresponds to a specified signal span.
Stability	The quality of an instrument or sensor to maintain a consistent output when a constant input is applied.
Strain Gauge	The Strain Gauge is a resistance bridge device where the bridge value alters linearly and proportionally to the force exerted on it – be it pressure, torque or load. The ICA is designed to convert this change in the of the Strain Gauge to a proportional electrical signal.
Strain Gauge Amplifier	The ICA is essentially a type of Signal Conditioner that it conditions (alters) the input signal from a strain gauge to an electrical output
Torque Transducer	The Torque Transducer is one of a series of Strain Gauge sensors that the ICA input is designed to accept.
Wheatstone Bridge	A network of four resistance's, an emf source, and a galvanometer connected such that when the four resistance's are matched, the galvanometer will show a zero deflection or "null" reading.
Zero	Zero is otherwise identified as OFFSET. It relates to the proportional output to the sensor input. Calibration of the ICA is determined by setting the Span (Gain) and Zero (Offset).
Zero Adjustment	The ability to adjust the display of a process or strain meter so that zero on the display corresponds to a non-zero signal.
Zero Offset	The difference between true Zero and an indication given by a measuring instrument. See Zero Suppression.
Zero Suppression	The Span is Offset from Zero (Zero Suppressed) such that neither limit of the Span will be Zero. For example, an instrument which measures a load of a 100kG Span from 400kG to 500kG is said to have 400kG Zero Suppression.
Units	
AC	Alternating Current
DC	Direct Current
Hz	Hertz (Frequency)
kHz	kilohertz (Frequency)
mA	milliamps
mm	millimetres
SC	Signal Conditioner
ICA	Strain Gauge Amplifier
V	Volts
mV	Millivolt

## Chapter 8 Specifications for ICA3 Load Cell Amplifiers

**Table 8.1 ICA3 – ± 10 Volts DC Output**

Parameter	Minimum	Typical	Maximum	Units
Power supply (reverse protected)	±13	-	±15	V DC
Bridge excitation	-	8	-	V
Bridge resistance	350	-	-	Ohms
Bridge sensitivity	0.5	2.5	30	mV/V †
Output load	5000	-	-	Ohms
Band width	0	-	1000	Hz
Zero temperature stability	-	0.002	-	%/ °C
Span temperature stability	-	0.005	-	%/ °C
Gain adjustment (Pot - fine adj.)	-	±8	-	%FS
Offset adjustment (Pot - fine adj.)	-	±2	-	% FS
Linearity	-	0.02	-	%FS
Operating temperature range	-40	-	+85	°C
Humidity	-	-	95	%RH

FS = Full Scale.

† set by calibration resistor.

### **Environmental Approvals**

EMC Emissions	EN 50 081-1	:1992 (Light industrial)
EMC Emissions	EN 50 081-2	:1992 (Heavy industrial)
EMC Immunity	EN 50 082-1	:1992 (Light industrial)
(RF Field Test 100 ppm of reading over 30 to 500MHz)	EN 50 082-2	:1992 (Heavy industrial)
(RF Field Test 500 ppm of reading over 30 to 500MHz)		
Low Directive	IEC 1010, EN 61010	

## Other Mantracourt Products

www.mantracourt.co.uk

### Signal Conditioning

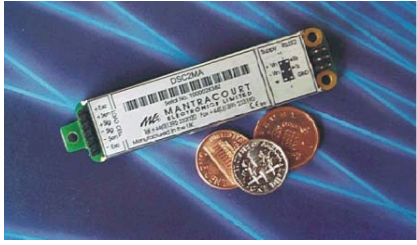
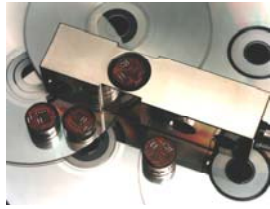
<p><b>SGA</b> STRAIN GAUGE AMPLIFIER</p> <ul style="list-style-type: none"> <li>• Connect up to 4 strain gauges</li> <li>• Proportional mA and/or Voltage output</li> <li>• Simple DIL switch configuration</li> <li>• Set Sensitivity and Low pass filter and output</li> <li>• Simple - Reliable - Rugged</li> </ul>	<p><b>RCA15</b> RACK MOUNTED INTELLIGENT STRAIN GAUGE AMPLIFIER Complete MULTI-CHANNEL system for Strain gauges.</p> <ul style="list-style-type: none"> <li>• Relay and/or serial outputs per channel</li> <li>• Multidrop serial link</li> <li>• 19" Eurorack x 3U high.</li> <li>• Capability similar to the ADW 15.</li> <li>• High integrity / compact Data acquisition unit</li> </ul>
<p><b>LCA</b> IN-LINE INTELLIGENT STRAIN GAUGE AMPLIFIER</p> <ul style="list-style-type: none"> <li>• 2 Set Points</li> <li>• 4 to 20 mA AND 0 to 10 V (isolated) outputs</li> <li>• RS 232/485 Communications port</li> <li>• On-Board easy to use Programmer</li> <li>• Auto tare–Auto calibrate–and much more.....</li> </ul>	<p><b>ADW15 Mantraweigh</b> 72 mm DIN Module – Display &amp; Controller</p> <ul style="list-style-type: none"> <li>• 10 mm LED Display (Configurable)</li> <li>• Sensitivity from 0.5 mV to 200 mV/V</li> <li>• 10 V @150 mA Excitation</li> <li>• Isolated I/O100mSec sample rate</li> <li>• Set Point Relays</li> <li>• 4 to 20 mA Output</li> <li>• Programmable via keypad</li> </ul>
<p><b>FIELD BUS CONNECTIVITY IN TWO EXCELLENT PACKAGES</b></p>	
<p><b>DSC The Digital Strain Card</b></p>	<p><b>'D'Cell The 'in-cell' Digital Strain Puck</b></p>
	
<p><b>Mount this package adjacent to the strain gauge</b></p>	<p><b>Mount this package directly into the strain gauge pocket</b></p>
<p><b>Plug-in-and-go-sensor</b></p>	<p><b>High accuracy</b></p>
<ul style="list-style-type: none"> <li>• Integrate the electronics with the load cell,</li> <li>• remove the cost, space and bother of additional electronics and have a direct output</li> <li>• provided in</li> <li>• <b>REAL ENGINEERING UNITS.</b></li> </ul>	<ul style="list-style-type: none"> <li>• A quantum leap in the quality of measurement.</li> </ul>
	<ul style="list-style-type: none"> <li>• Accuracy (1 part in half a million)</li> <li>• Temperature compensated</li> <li>• Unwanted Signal noise filter</li> <li>• Sensor specific calibration</li> <li>• Elimination induced noise on signals</li> </ul>



In the interests of continued product development, Mantracourt Electronics Limited reserves the right to alter product specifications without prior notice.



Doc No. ME 0131 MD 2E

Code No. 517-162 Issue 1.1

24.05.02